

Dimensions
Mechanical Properties
Application Data

ISO 10642 : Hexagon Socket Countersunk Head Cap Screws

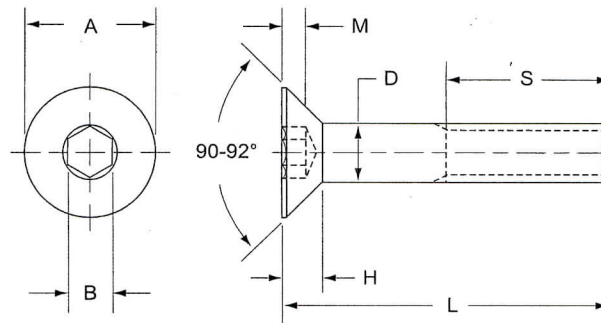

Dimensions (mm)

Nom. Size	A	D	B	M min.	S min.	H max.	Da max.	F max.	R. S. Torque (NM)	
									12.9	10.9
M3	5.54 - 6.72	2.86 - 3.00	2.020 - 2.080	1.10	18	1.86	3.30	0.25	1.35	1.15
M4	7.53 - 8.96	3.82 - 4.00	2.520 - 2.580	1.50	20	2.48	4.40	0.25	3.10	2.70
M5	9.43 - 11.20	4.82 - 5.00	3.020 - 3.080	1.90	22	3.10	5.50	0.30	6.10	5.40
M6	11.34 - 13.44	5.82 - 6.00	4.020 - 4.095	2.20	24	3.72	6.60	0.35	10.5	9.15
M8	15.24 - 17.92	7.78 - 8.00	5.020 - 5.140	3.00	28	4.96	8.54	0.40	26.0	22.0
M10	19.22 - 22.40	9.78 - 10.00	6.020 - 6.140	3.60	32	6.20	10.62	0.40	52.0	44.0
M12	23.12 - 26.88	11.73 - 12.00	8.025 - 8.175	4.30	36	7.44	13.50	0.45	90.0	77.0
M14	26.52 - 30.80	13.73 - 14.00	10.025 - 10.175	4.50	40	8.40	15.50	0.50	143	122
M16	29.01 - 33.60	15.73 - 16.00	10.025 - 10.175	4.80	44	8.80	17.50	0.60	225	190
M20	36.05 - 40.32	19.67 - 20.00	12.032 - 12.212	5.60	52	10.16	22.00	0.75	440	371

Notes :

1. Thread Class : 5g6g for property class 12.9; 6g for other property classes.
2. Length Tolerance : See Table 2, Page 7.
3. R. S. Torque=Recommended Seating Torque.
4. Working Temperature : -50°C ~ + 300°C.

Mechanical Properties

Property Class	10.9	12.9
Hardness (HRC)	32-39	39-44
Tensile Strength (Mpa)	835 min.	980 min.
Decarburization and Carburization (see Page 17)	E = 2/3H1	E = 3/4H1

Flushness Gauge

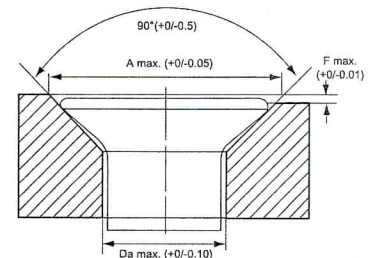

Typical Application Fixture

Flat socket head cap screws are designed for use in applications where the head cannot protrude above the mating parts. They are set in countersunk holes and the top of the head is flush with the surface of the assembly.

